

# A Multi-Layered Approach to Transmission Provision in Electric Power Networks

Marija Ilic milic@ece.cmu.edu  
Carnegie-Mellon University  
ECE and EPP Departments  
IMA Workshop, March 8, 2004

# Talk Outline

- Problem formulation as a function of industry structure
- Temporal Separation/Layering
  - Short-term provision and pricing
  - Long-term provision and pricing
  - Inter-temporal effects
- Spatial separation/Layering
  - Vertical unbundling
  - Horizontal unbundling/re-bundling
- Mechanisms/protocols for re-bundling
  - Temporal and/or spatial
- Complete markets

# Physical problem of interest

- The problem of delivering power by means of the electric power grid
- Basic relations and implied assumptions

# Sample Power Transmission System

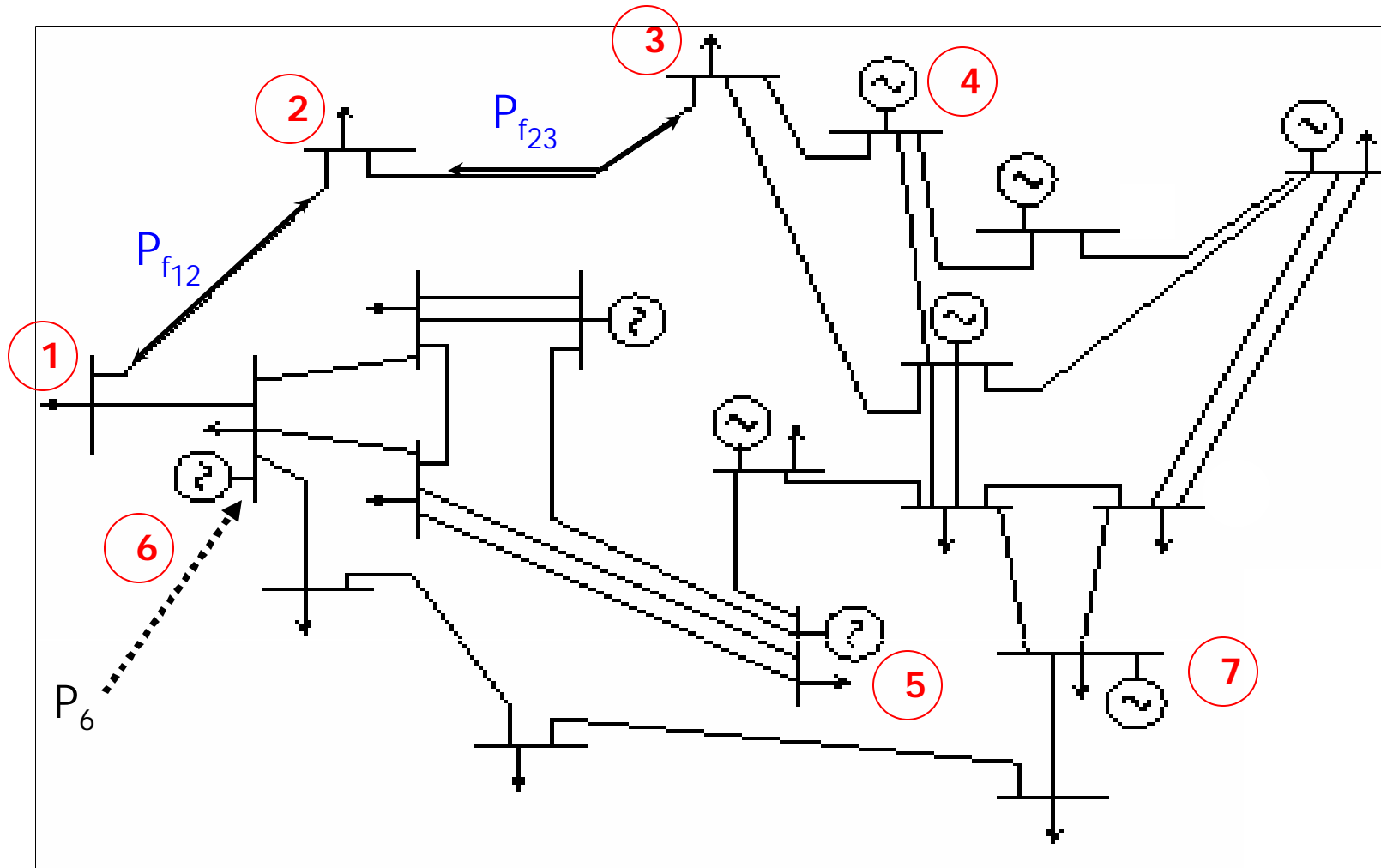

# Loop Flows and Real-Time Balancing

$$\begin{pmatrix} P_{f_{12}} \\ P_{f_{23}} \\ \cdot \\ \cdot \\ \cdot \end{pmatrix} = \mathbf{D} \times \begin{pmatrix} P_1 \\ P_2 \\ \cdot \\ \cdot \\ \cdot \\ \cdot \\ \cdot \end{pmatrix}$$

Capacity Constraint:

$$| P_{f_{ij}} | < P_{f_{ij}}^{\max}$$

Balancing Constraint:

$$\sum P_i = 0$$

Result:

Line Flows

TRANSMISSION

System Inputs:

Injections/Withdrawals

ENERGY

# Problem formulation as a function of industry structure

- Engineering problem of interest
- Several implementations
- Effects of implementation on
  - System performance
  - System users' performance

# Functional Unbundling of Regulated Utilities

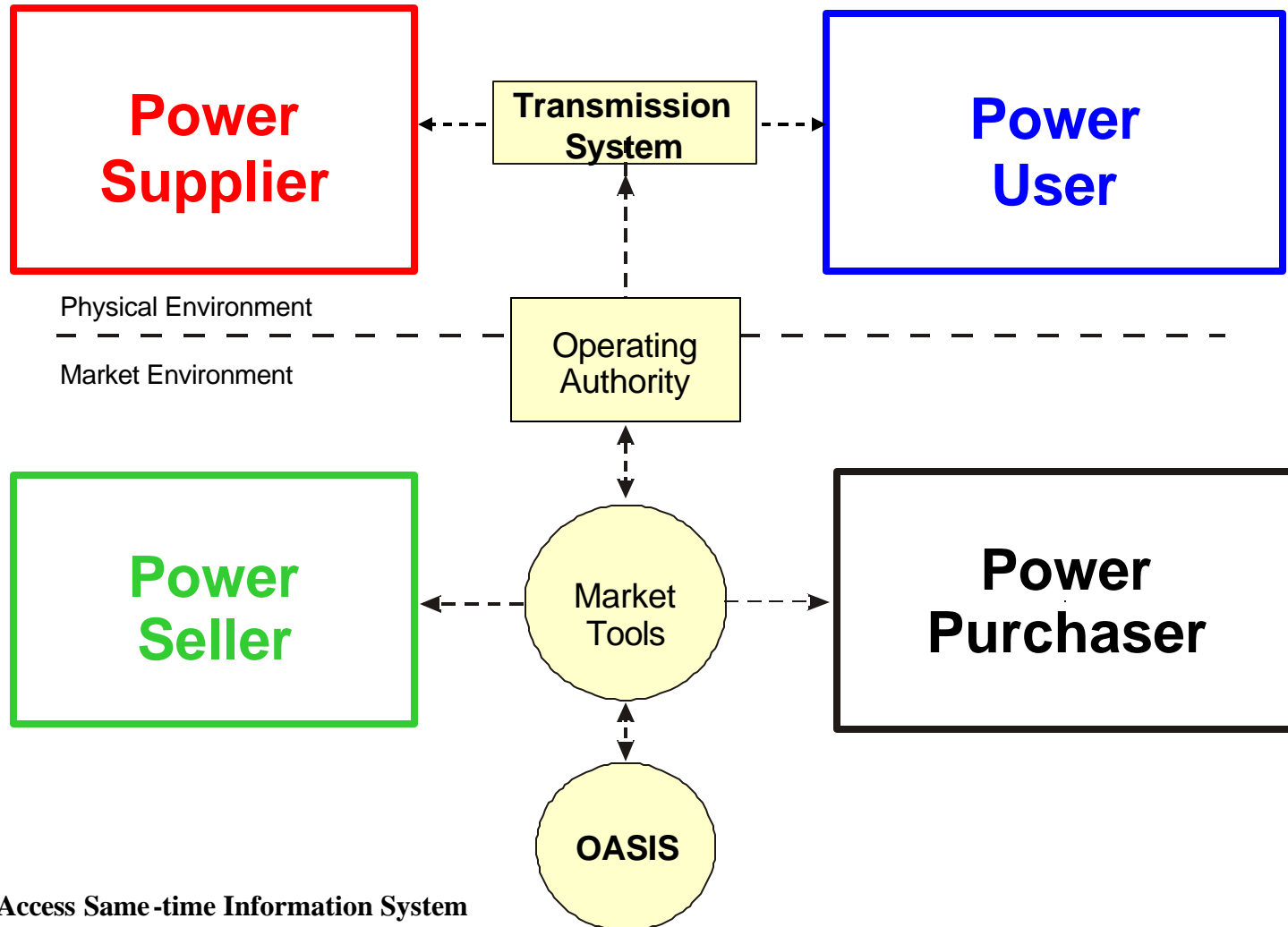

OASIS: Open Access Same-time Information System

# Several alternative implementations

- Pool-Co (centralized static optimization of total generation cost subject to flow constraints; OPF; LMPs)
- Multi-lateral energy trading subject to technical constraints (no delivery charges)
- Multi-layered iterative provision and pricing

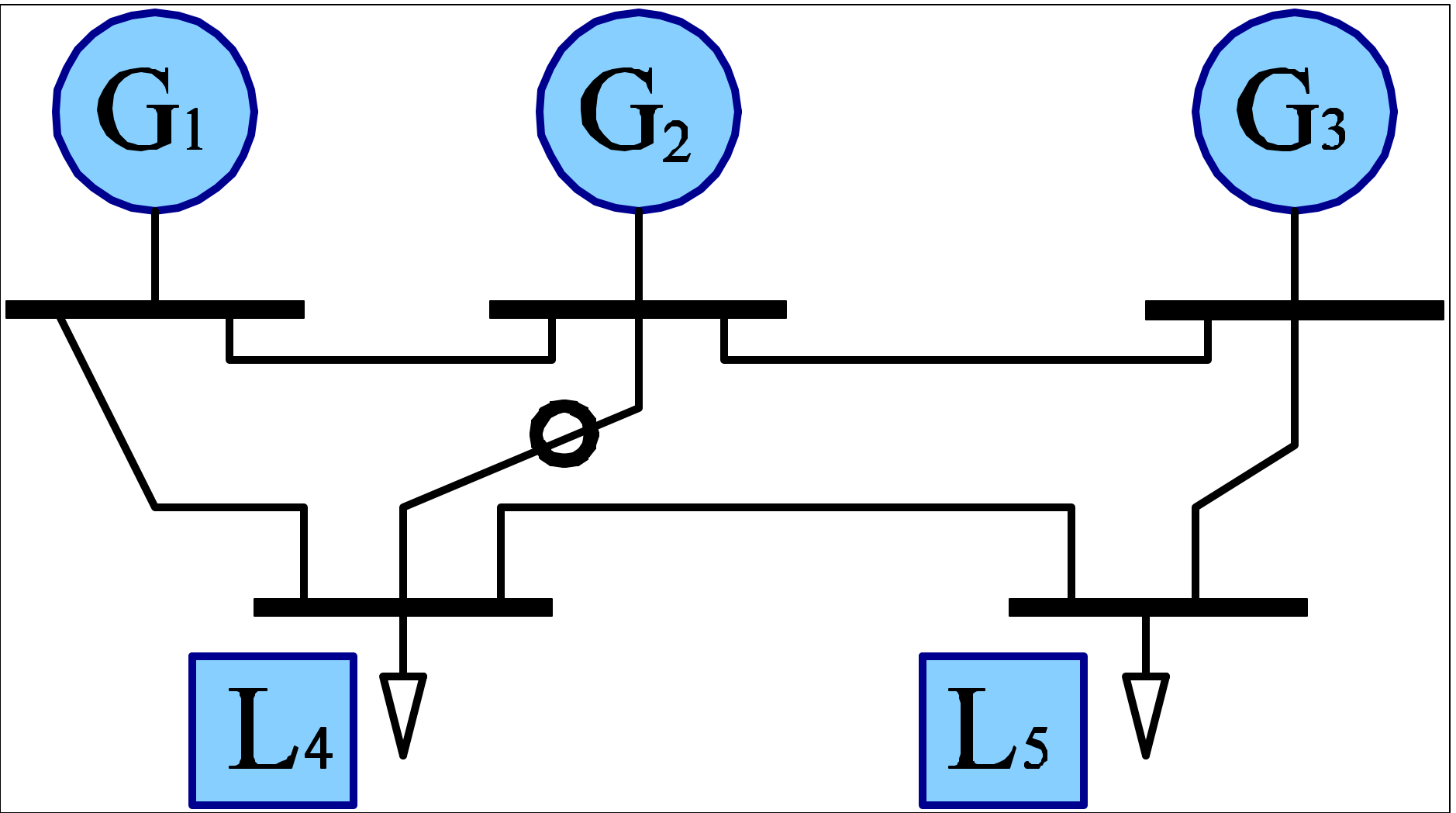

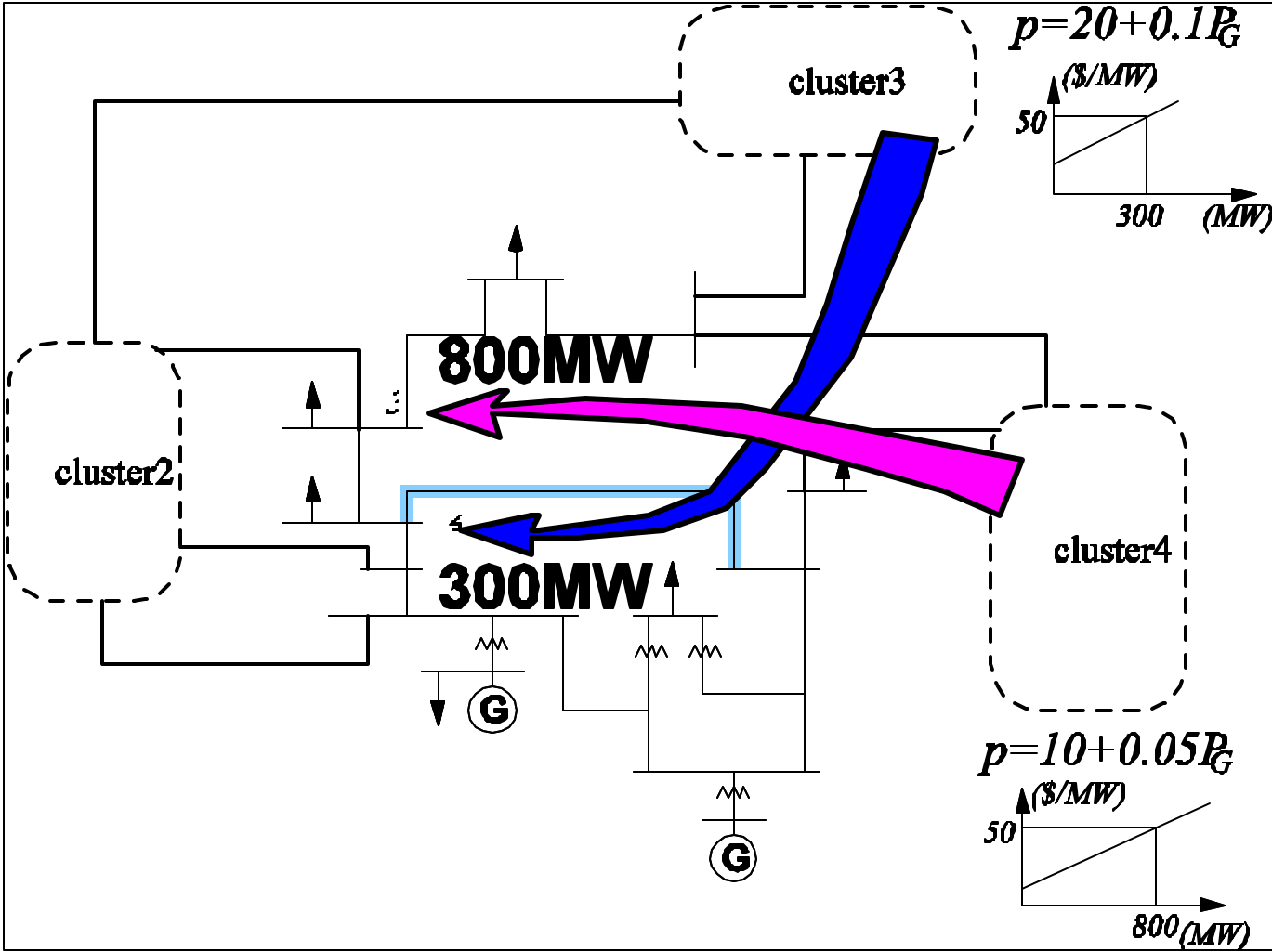

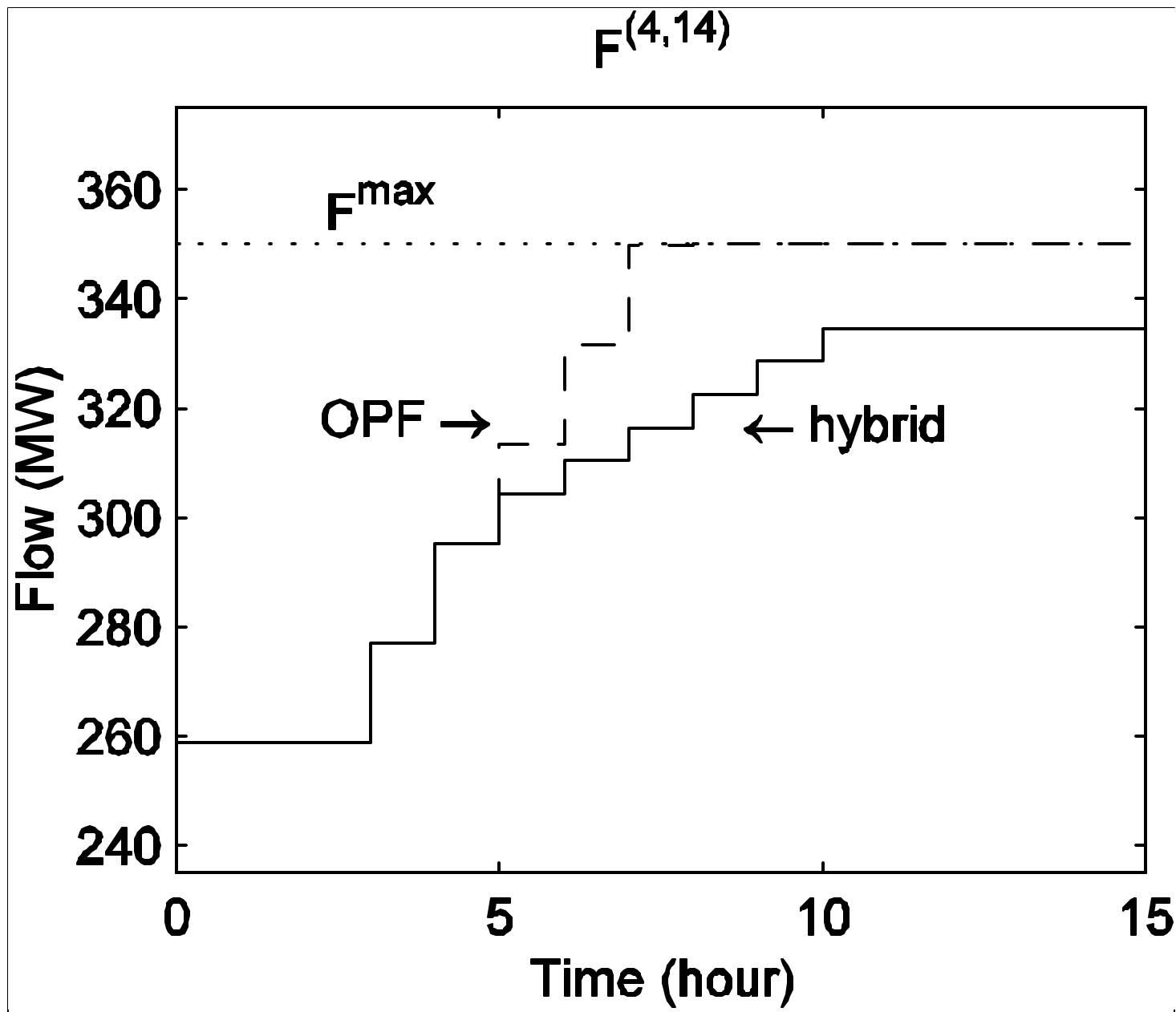

(a)  $P_{G\text{-cluster3}}$

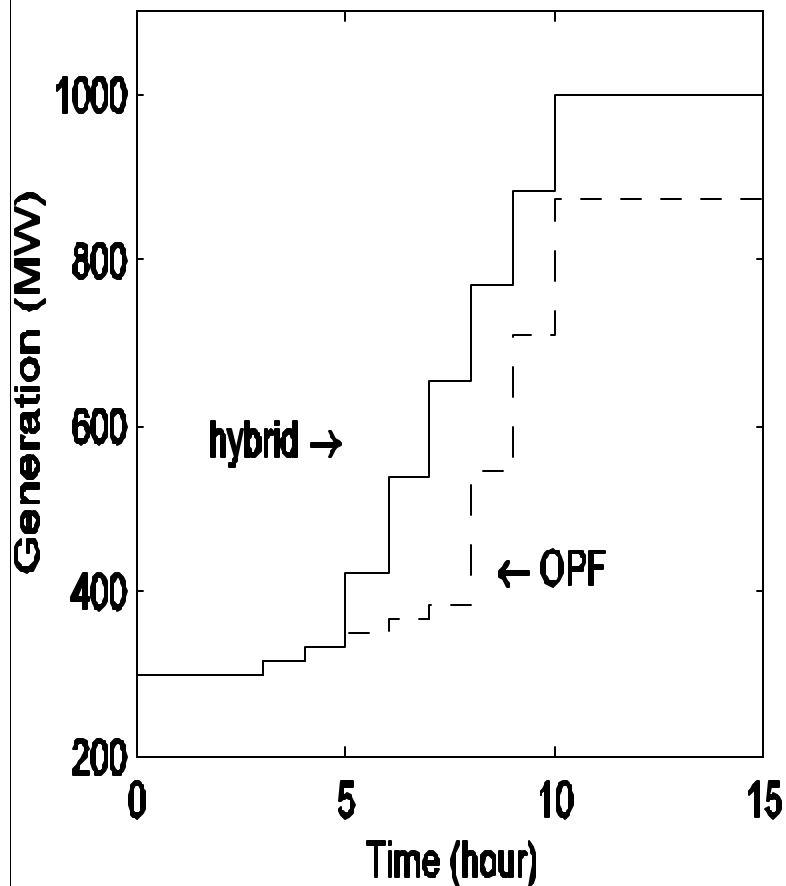

(b)  $P_{G\text{-cluster4}}$

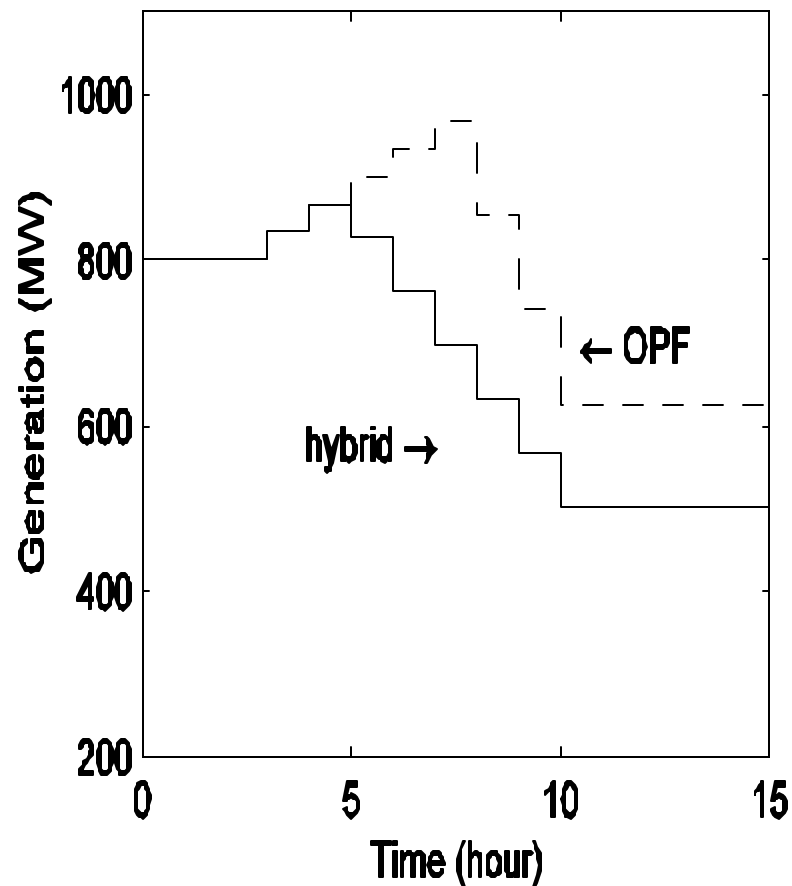

(a)  $P_{L3}$

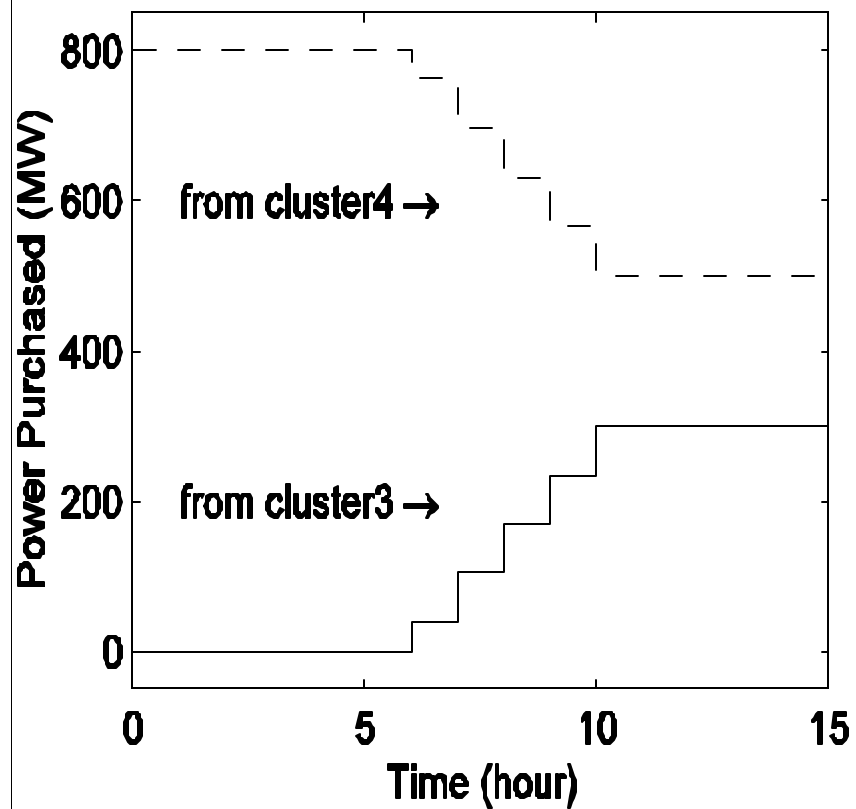

(b)  $P_{L4}$

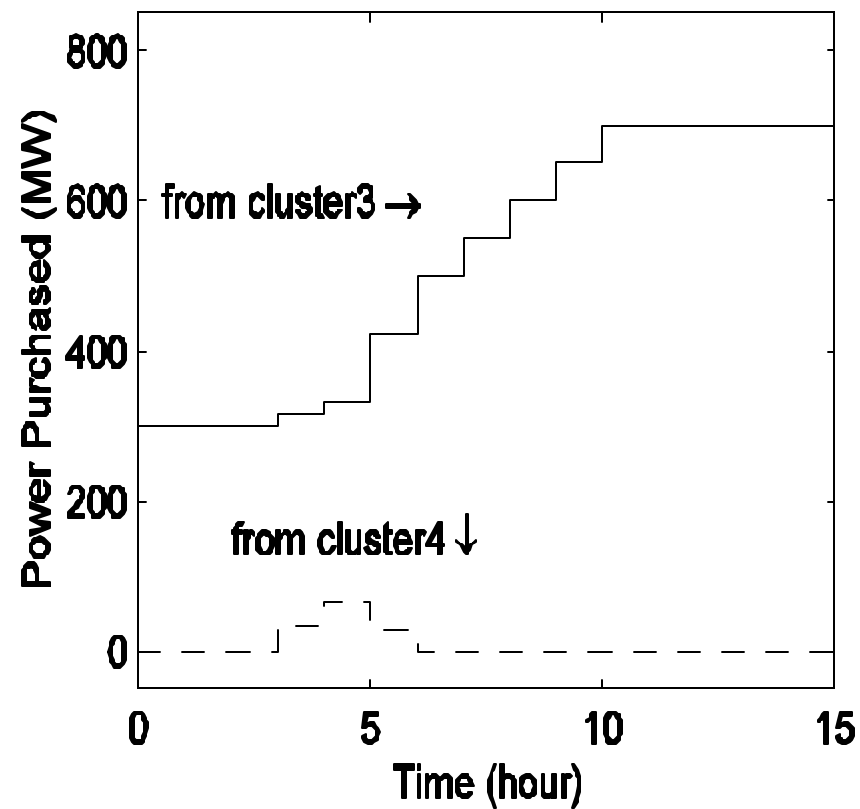

# An important result

- All three industry structures result in the same total system cost (theoretical and simulations-results)
- Critical assumptions: Linear (DC) relations between power injections and flows; linear inequality constraints (LP problem)
- Non-linear load flow constraints do NOT lend themselves to the same result (voltage constraints cannot be handled) (NLP problem)
- Topological changes (reliability) cannot be included (DP problem)

# Inter-temporal dependencies

- Typical load profile
- Need to balance power instantaneously
- Could be supplied either on the spot, or through long-term contracts
- Depending on how are uncertainties managed, very different effects on system-wide performance
- RESULTS VERY DIFFERENT DEPENDING ON HOW IS SYSTEM MANAGED UNDER TOPOLOGICAL CHANGES

# Stochastic Optimization Problem

$$\begin{aligned}
 \min_{P_{i,a}^G, I_{i,a}^G, I_l^T} & \int_{t_0}^T \dot{\lambda}_{i,a} \dot{\theta} e^{-rt} \left[ c_{i,a} \left( P_{i,a}(t) \right) + C_{i,a}^G \left( K_{i,a}^G(t), I_{i,a}^G(t), t \right) \right] dt \\
 & + \int_{t_0}^T \dot{\lambda}_l \dot{\theta} e^{-rt} \left[ C_l^T \left( K_l^T(t), I_l^T(t), t \right) \right] dt \\
 & - \int_{t_0}^T \dot{\lambda}_i \dot{\theta} e^{-rt} \left[ U_i \left( L_i(t), u_i(t) \right) \right] dt
 \end{aligned}$$

Technology
Investment
Uncertainty in Load

subject to

$$\frac{dK_l^T}{dt} = I_l^T(t) ; \frac{dK_{i,a}^G}{dt} = I_{i,a}^G(t) ; K_l^T(0), K_{i,a}^G(0); I_l^T(t), I_{i,a}^G(t) \geq 0$$

$$\dot{\lambda}_i H_{li} \left( P_{i,a}(t) - L_i(t) \right) \in K_l^T, P_{i,a}(t) \in K_{i,a}^G, \dot{\lambda}_{i,a} P_{i,a} = \dot{\lambda}_i L_i$$

# Resource Allocation

- Power Transmission Capacity Resource Allocation Problem
- Under deregulation:
  - Energy Markets (Generation and Consumption):  
Actual Power
    - ❖ Daily real-time trades in the spot market.
    - ❖ Long term bilateral contracts, forwards hedge against real time volatility.
    - ➡ Tools are being developed

WHAT IS THE VALUE OF TRANSMISSION?  
WHAT ALLOCATION YIELDS THE HIGHEST VALUE?

# Electric System Time Line: Market and Physical<sup>1</sup>

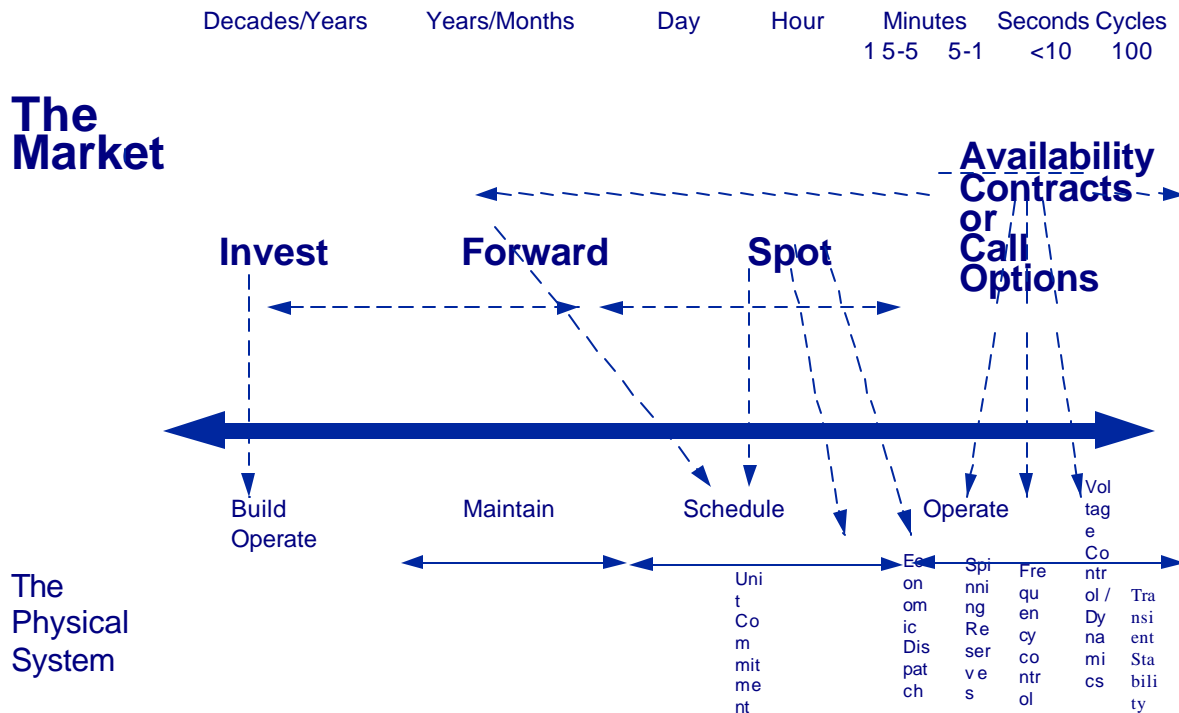

<sup>1</sup> Shimon Awerbuch, Michael Crew, Paul Kleindorfer

# Research Challenge

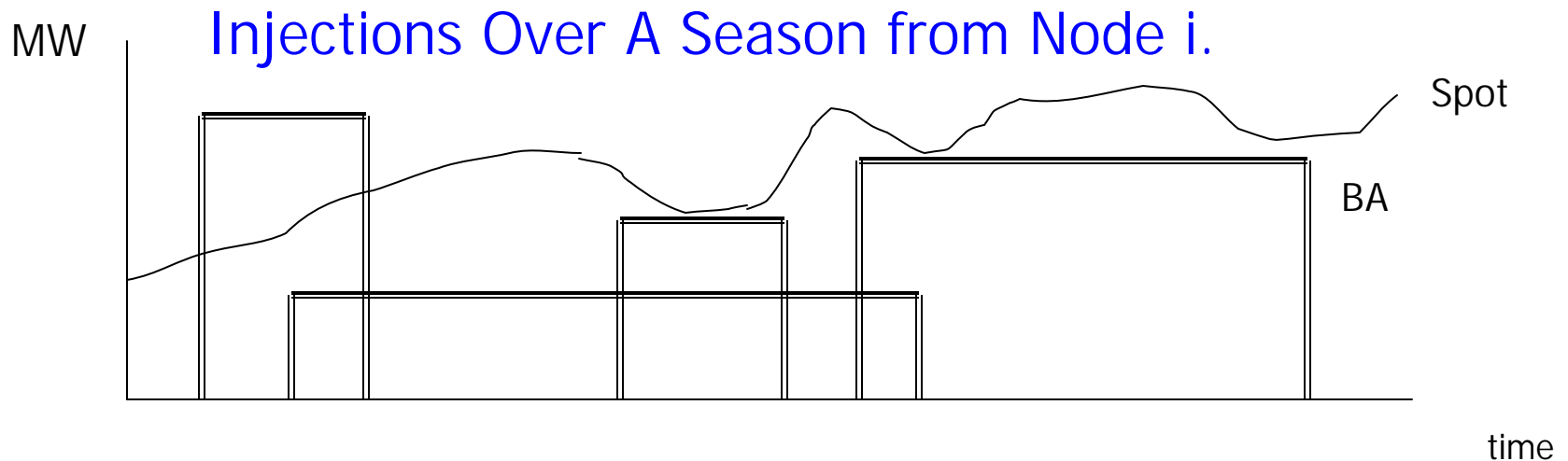

- Mapping the requests from different energy market inputs to requests for transmission service:
  - ? Long-Term delivery commitment ? Spot Market
  - Formulate **TRANSMISSION CAPACITY RESOURCE ALLOCATION**
- Who makes the decision anyways:
  - ? Transmission Service Provider (TSP) ? System Users
  - CENTRALLY COORDINATED or DISTRIBUTED**
- Software Implementation – Dynamic Programming

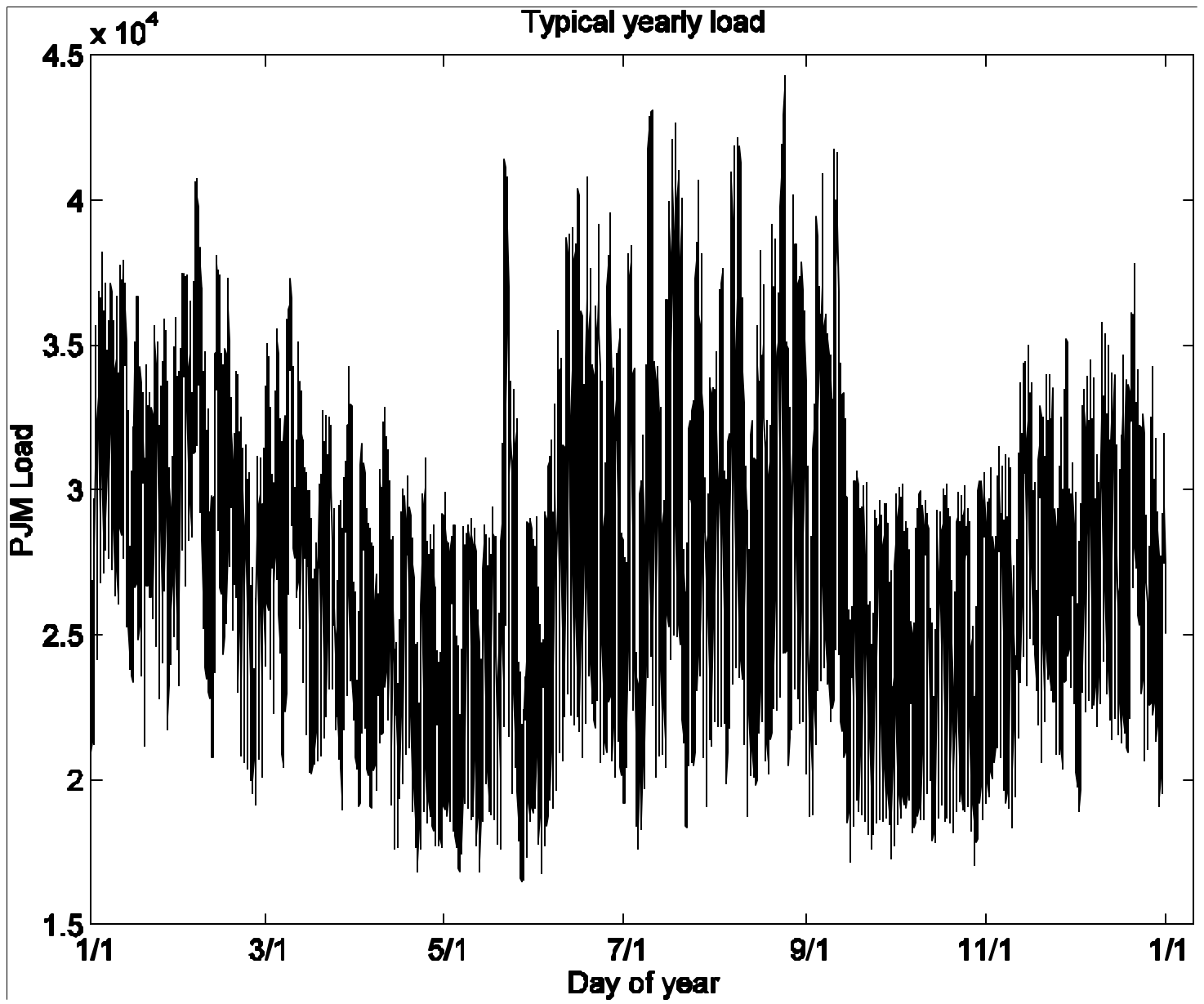

# Full Tree of Uncertainties

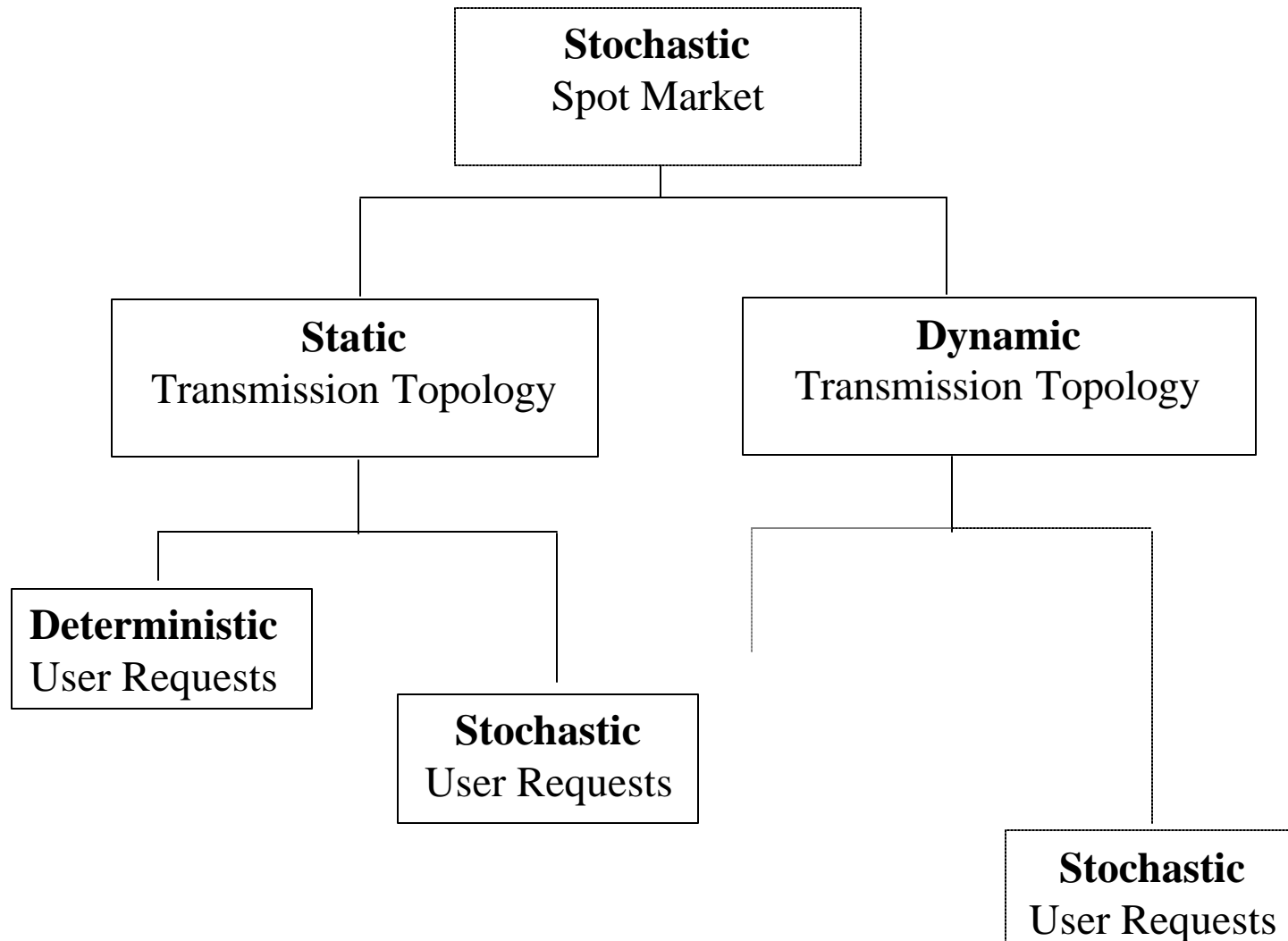

# Centrally Coordinated Decision Making by Transmission Service Provider (TSP)

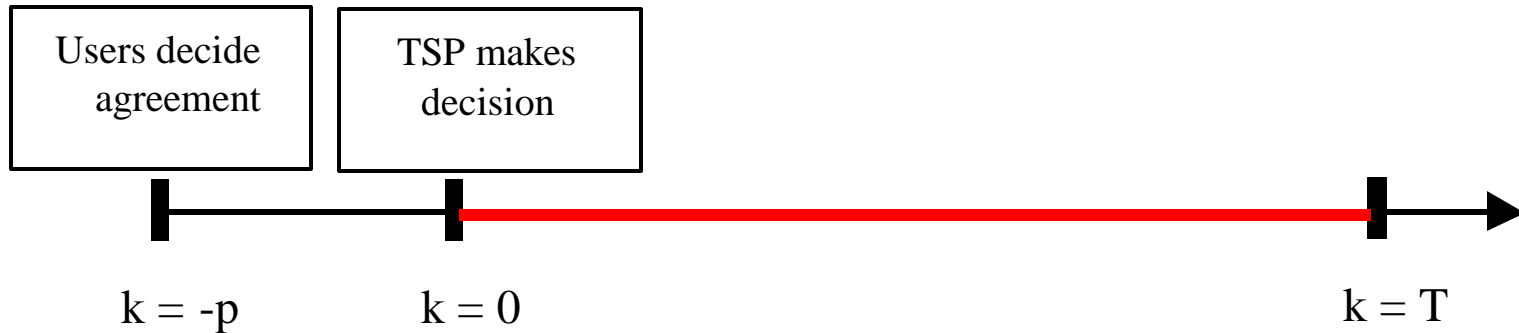

- BA

Quantity  
Price  
Start Time  
End Time

Communicate  $\therefore$  **Deterministic**

Do not  
Communicate  $\therefore$  **Stochastic**

- Spot

**Stochastic**

# TSP Optimization (Dynamic Topology)

$$R^{season} = \sum_k (R^{BA}[k] + R^S[k] - Compensation[k])$$

$$\arg \max_{U, Y, S, W_s, \Pi} E \{ R^{season} \} =$$

$$= \sum_k \left[ \begin{array}{l} \mathbf{e}_Y \left\{ \sum_{ij} u_{ij}[k] P_{ij}^Y[k] Q_{ij}^Y[k] \right\} + \\ \sum_{ij} P_{ij}^X[k] Q_{ij}^X[k] + \\ \mathbf{e}_{W_s, Y, \Pi} \left\{ \sum_{ij} (P_i^{W_s}[k] - P_j^{W_s}[k]) Q_{ij}^{W_s} \right\} \end{array} \right] - \sum_k \left[ \begin{array}{l} \mathbf{e}_{W_s, Y, \Pi} \left\{ \sum_{ij} (1 - p_{ij}[k]) \cdot u_{ij}[k] P_j^S[k] Q_{ij}^Y[k] \right\} \\ \mathbf{e}_{W_s, Y, \Pi} \left\{ \sum_{ij} (1 - p_{ij}[k]) \cdot P_j^S[k] Q_{ij}^X[k] \right\} \end{array} \right]$$

$$\forall i, j \in \{N_G, N_L\}, i \neq j$$

$$p_{ij}[k] = p_{ji}[k] = \begin{cases} 1 \rightarrow \text{Operational Line} \\ 0 \rightarrow \text{Failed Line} \end{cases} \quad Q_{Gi}[k] = \infty$$

$W_s$  : Random Disturbance      X : Current System Parameters

S : Spot Market

$\Pi$  : Physical System Status

# Spatial complexities

- Very large networks
- No direct control of power flows between the sub-networks
- Requirements for “open access” (FERC)
- Various levels of granularity: Nodes, zones, administrative boundaries (utilities, control areas)
- Without aggregation it is impossible to “learn” how to use the network in a bottom-up way (too combinatorial)

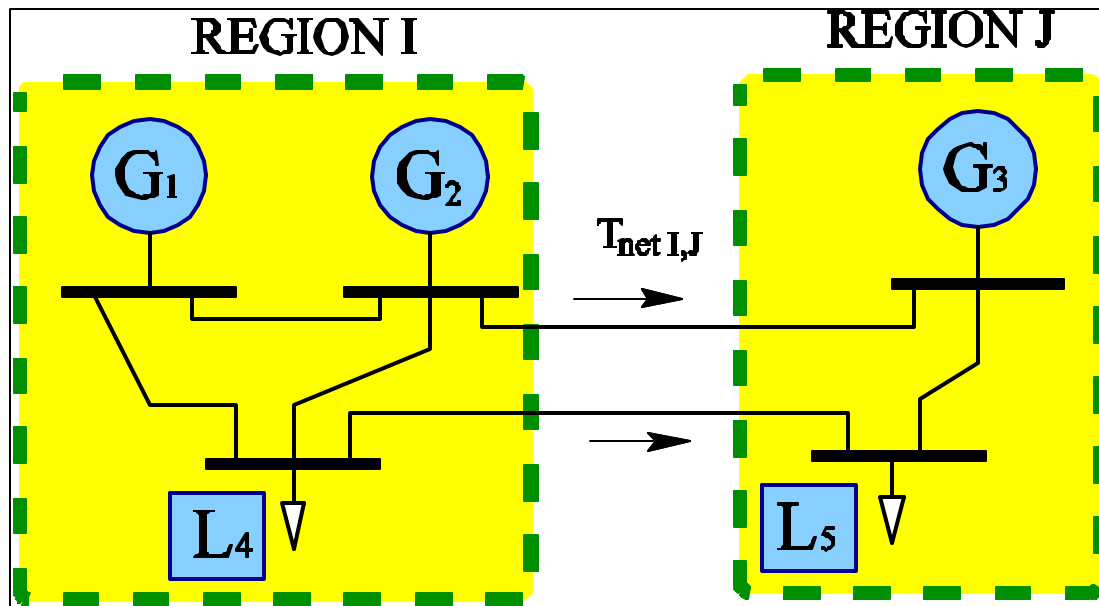



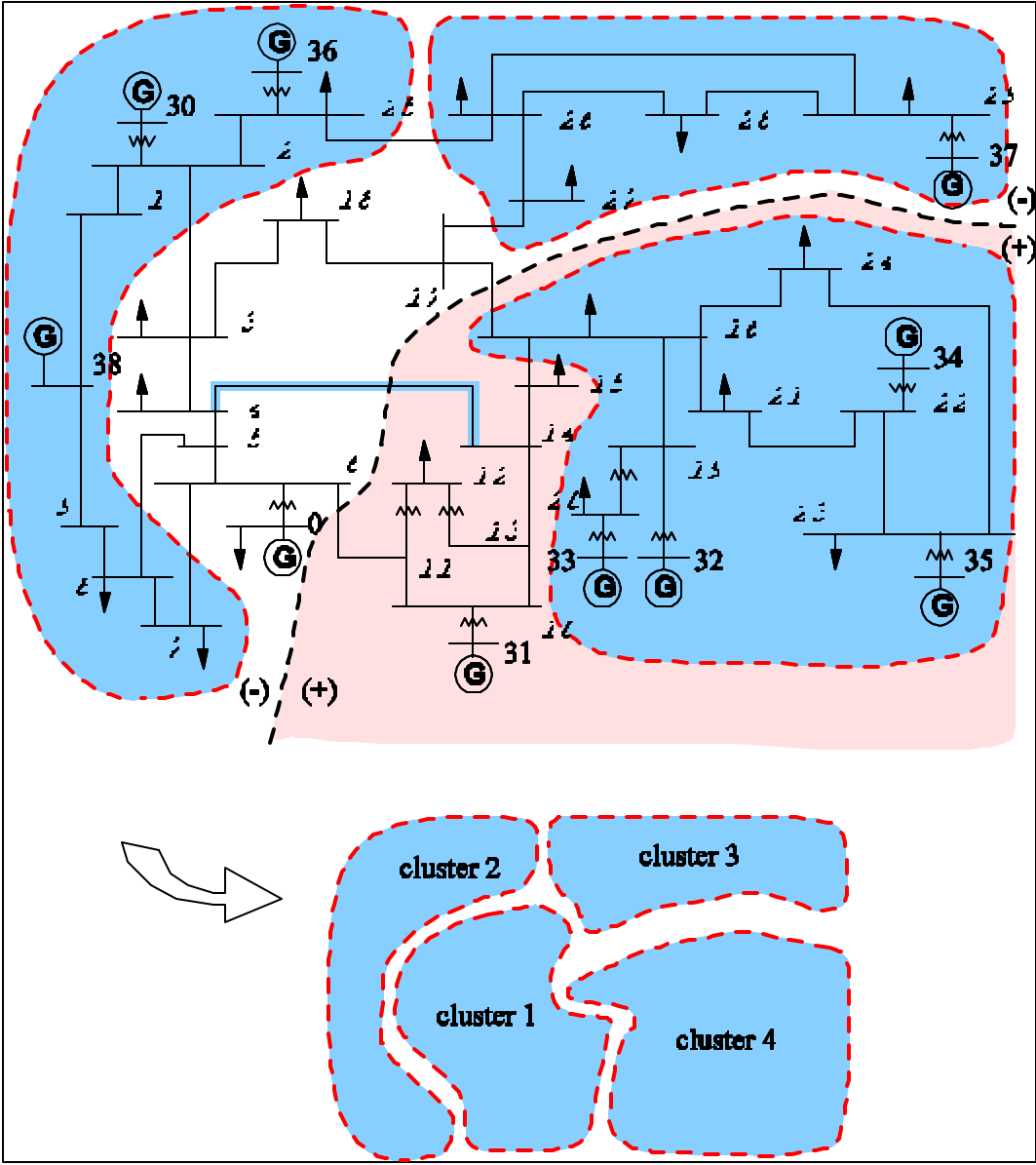



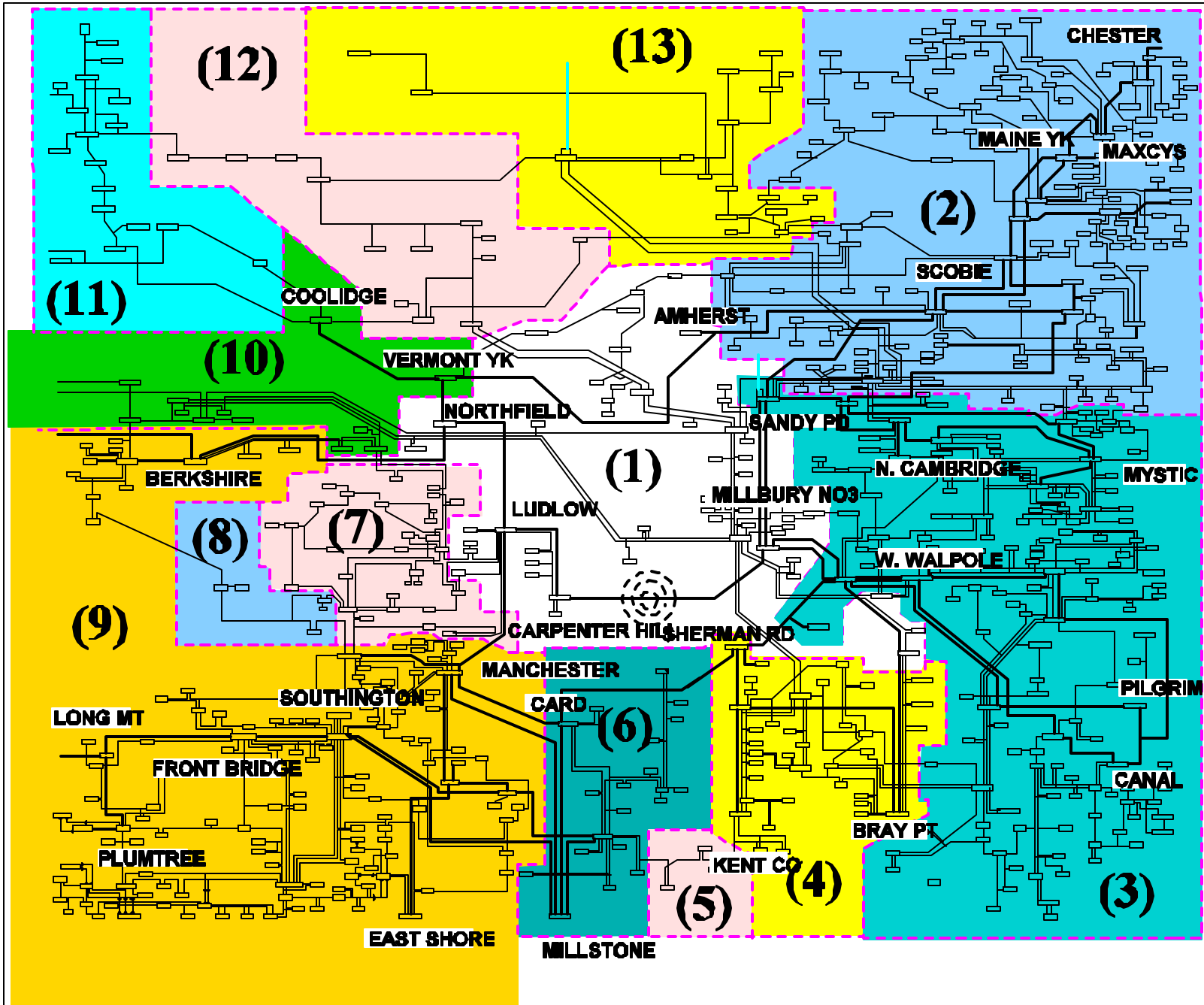

# Dynamic aggregation

- Zones—sub-groups of end-users which contribute to the line flow constraint of interest the same way (Zone 1—the largest effect; Zone 2-smaller effect, ..)
- Could be used for spatial simplifications; extremely relevant for market transparency and liquidity;
- Open questions: Coordination of zones and/or control areas to implement “open access” delivery

# Critical open problems

- Design of complete markets for managing power delivery at value (including physical reliability-related risks) over a wide range of time horizons and their inter-temporal dependencies;
- The effect of decentralization (coordination needed for system-wide efficiency; could be through price incentives, and/or engineering rules);
- Tools for re-bundling over time and space to facilitate delivery markets

# Dynamic Protocol --- Utility Level

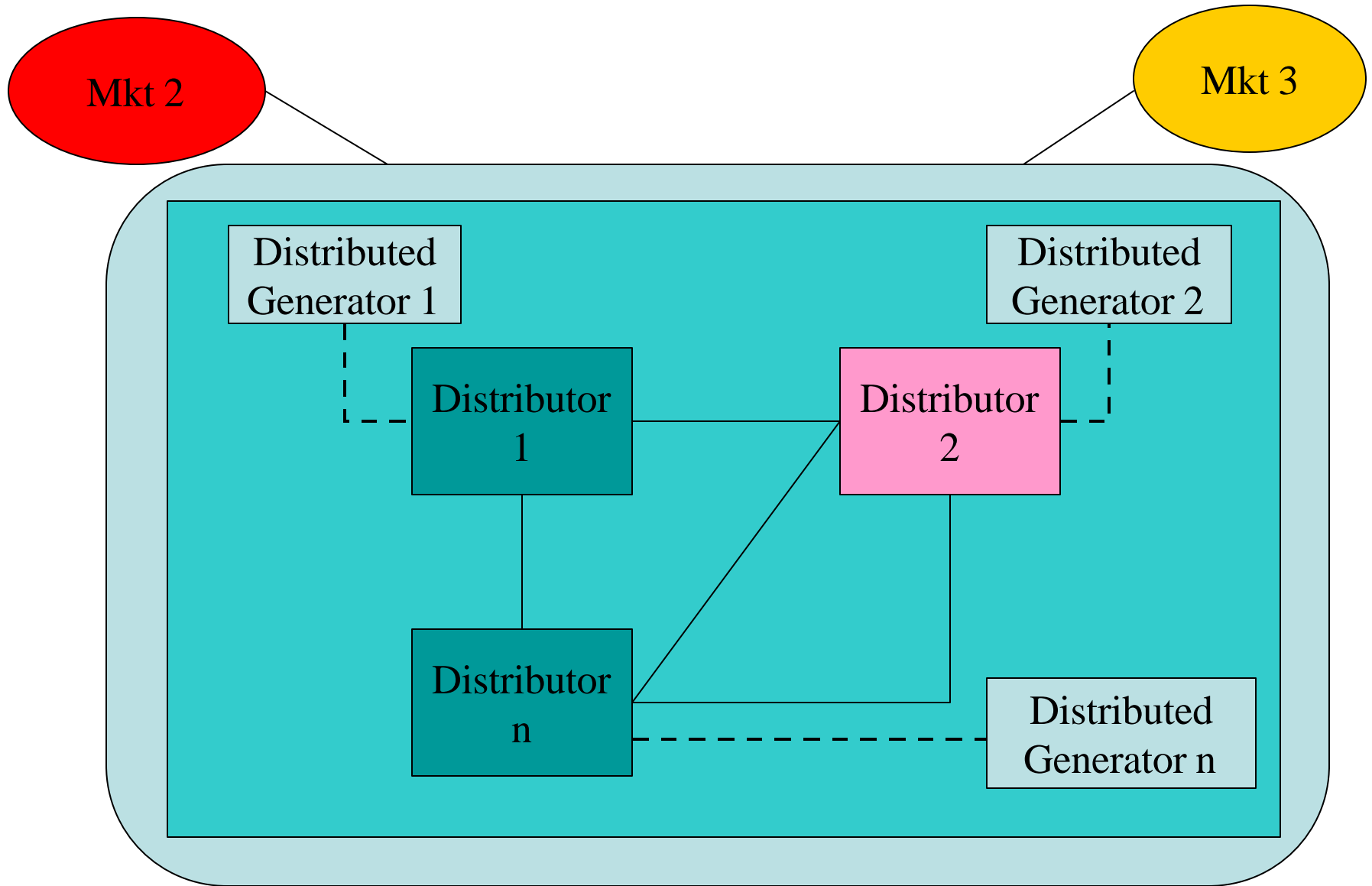

# Dynamic Protocol --- Energy Market Level

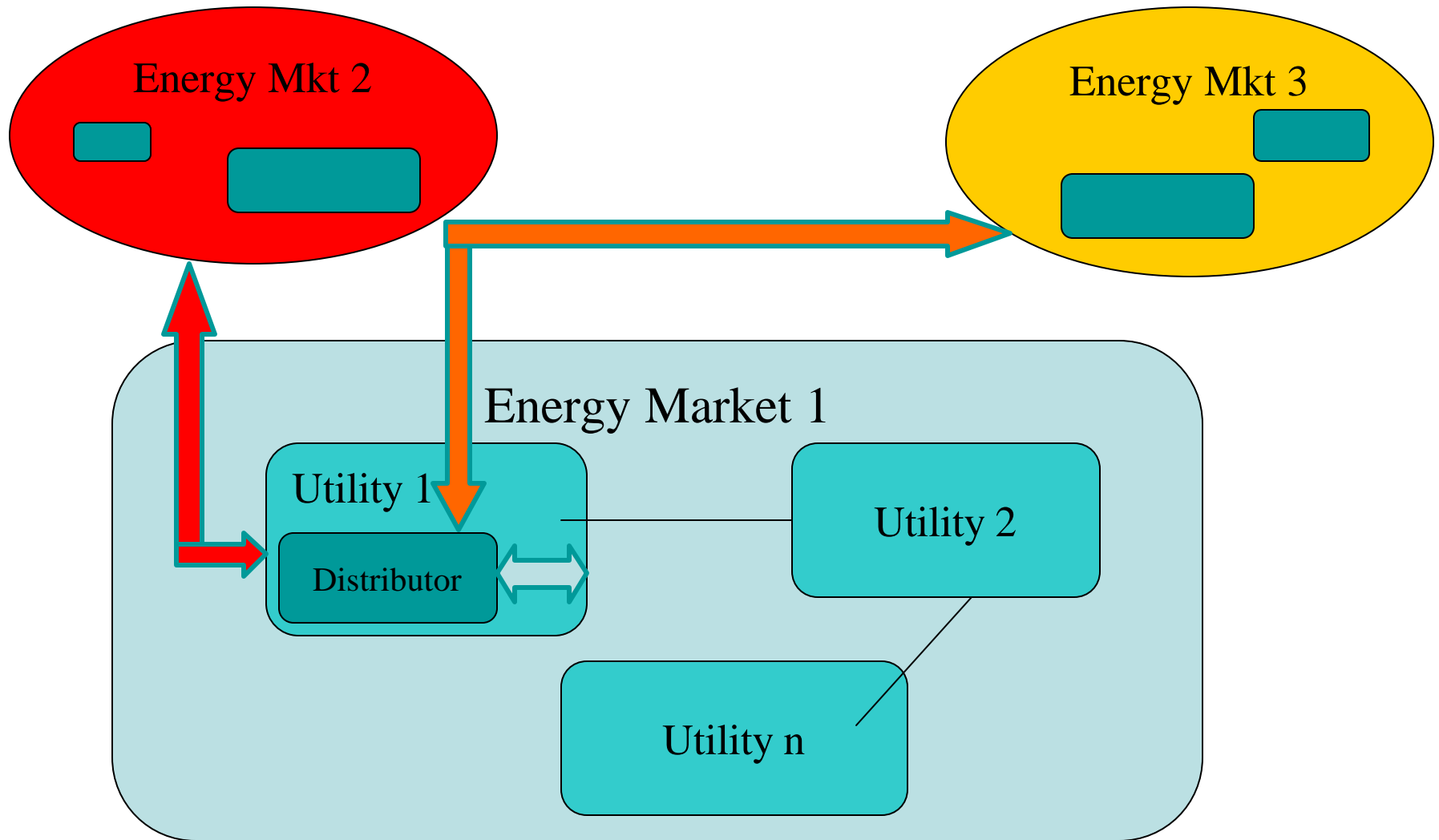

# Dynamic Protocol --- Energy Market Level

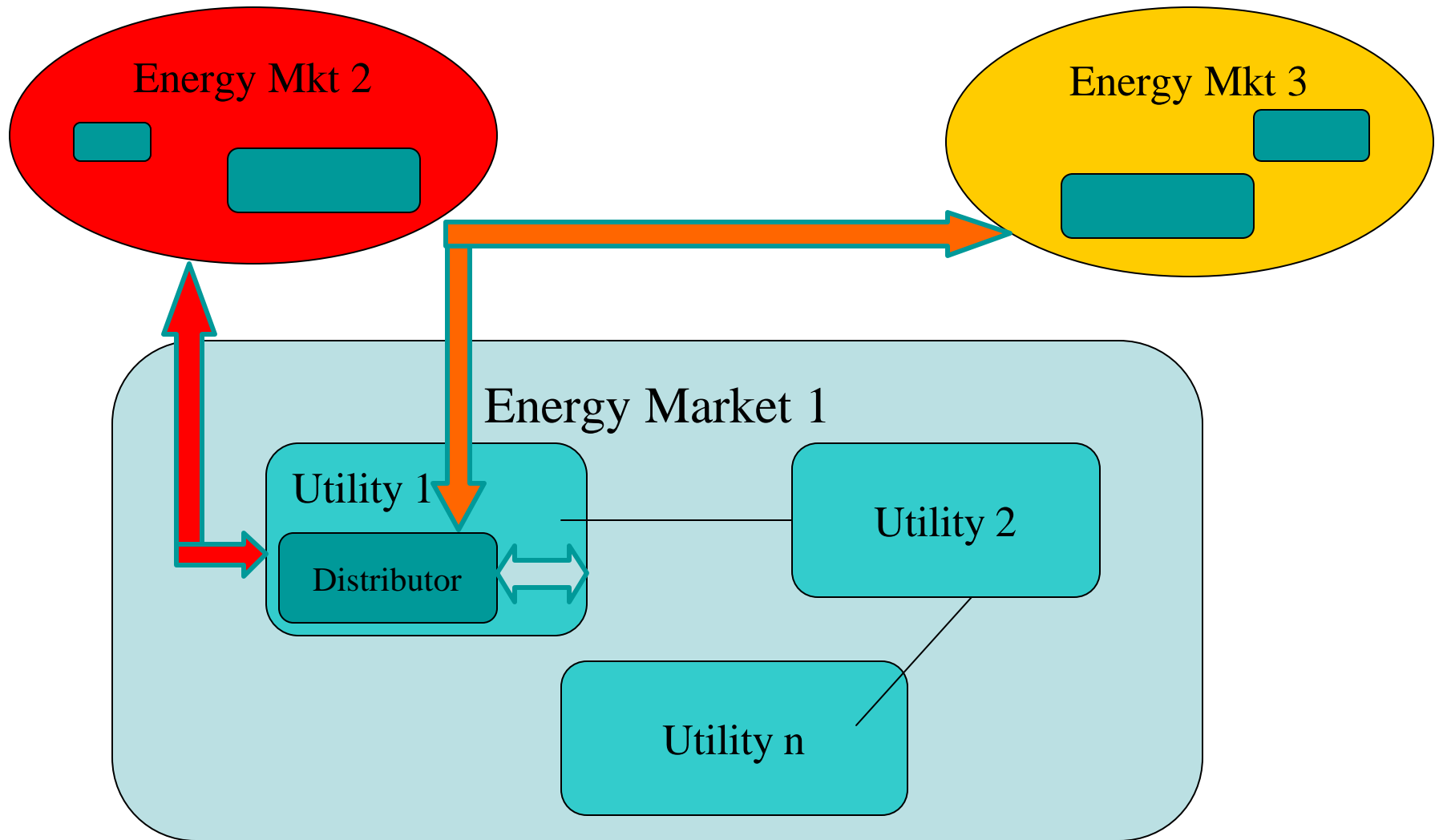

# Dynamic Protocol --- Multi Market Level

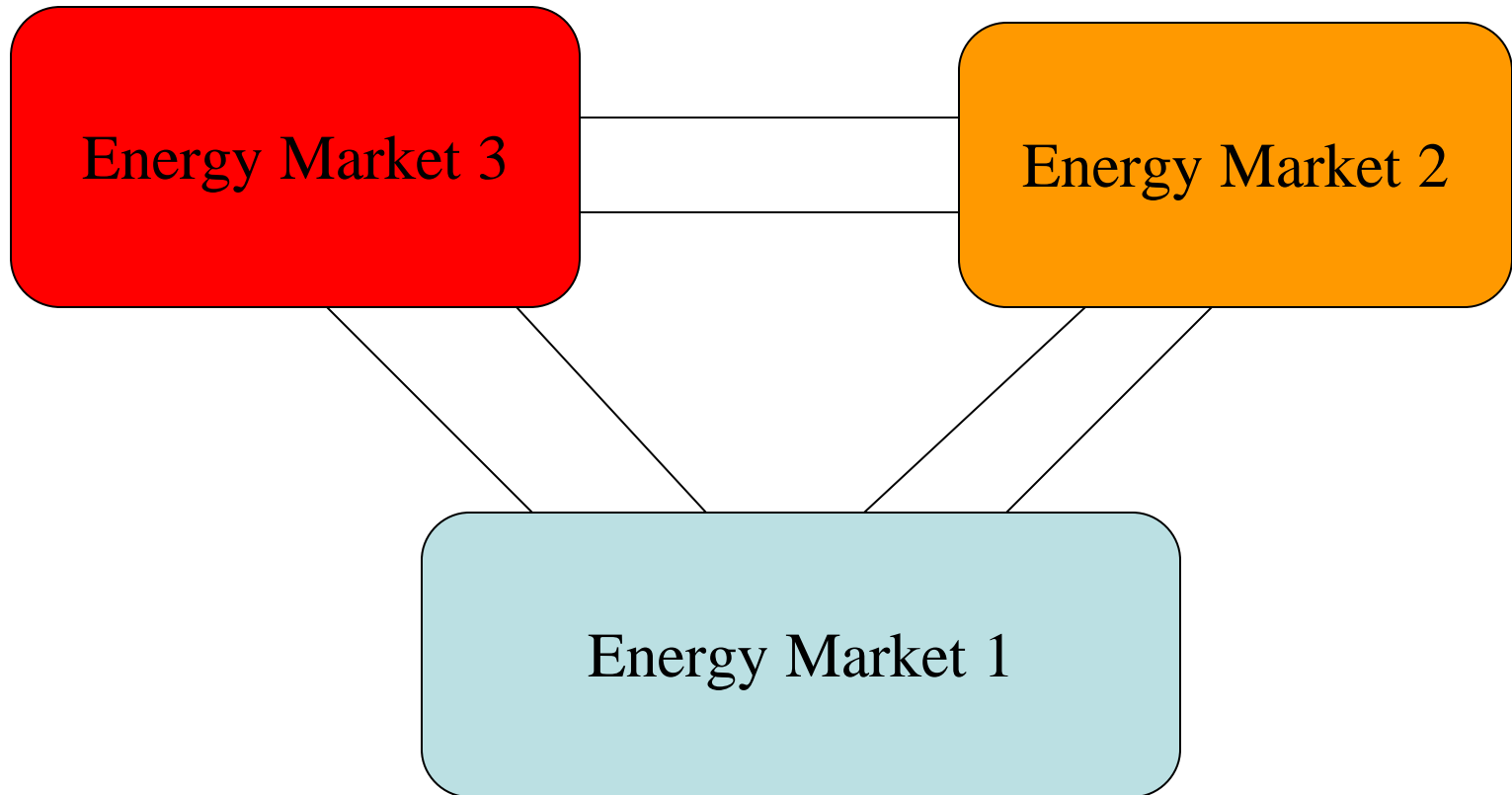

## (Possibly) the biggest obstacle

- Lack of incentives to design delivery markets in a systematic way (I(SO)s primarily concerned with reliability)
- At present no-ISOs are actively working toward value-based reliability management